

Operating instructions for the system user

VIESSMANN

With constant temperature or weather-compensated control unit



VITODENS 050-W



Safety instructions

For your safety



Please follow these safety instructions closely to prevent accidents and material losses.

Safety instructions explained



Danger

This symbol warns against the risk of injury.



Please note

This symbol warns against the risk of material losses and environmental pollution.

Note

Details identified by the word "Note" contain additional information.

Target group

These operating instructions are designed for heating system users. This appliance can also be operated by children 8 years and older, as well as by individuals with reduced physical, sensory or mental faculties or those lacking in experience and knowledge, provided such individuals are being supervised or have been instructed in the safe use of this appliance and any risks arising from it.



Please note

Supervise children in the proximity of the appliance.

- Never permit children to play with the appliance.
- Cleaning and maintenance must not be carried out by unsupervised children.

Connecting the appliance

- Connection and commissioning of the appliance may only be carried out by authorised contractors.
- Only operate the appliance with suitable fuels.
- Adhere to the electrical connection requirements.
- Modifications to the existing installation may only be carried out by authorised contractors.



Danger

Incorrectly executed work on the heating system can lead to life threatening accidents.

- Work on gas installations must only be carried out by a registered gas fitter.
- Work on electrical equipment must only be carried out by a qualified electrician.

Working on the appliance

- When adjusting settings and carrying out work on the appliance always follow the guidelines in these operating instructions. Additional work on the appliance may only be carried out by authorised contractors.
- Never open the appliance.
- Never remove the cladding.
- Never remove or change additional parts or installed accessories.
- Never open or retighten pipe connections.

For your safety (cont.)



Danger

- Hot surfaces can cause burns.
- Never open the appliance.
 - Never touch the hot surfaces of uninsulated pipes, fittings or flue pipes.

If you smell gas



Danger

- Escaping gas can lead to explosions which may result in serious injury.
- Do not smoke. Prevent naked flames and sparks. Do not switch lights or electrical appliances on or off.
 - Close the gas shut-off valve.
 - Open windows and doors.
 - Evacuate any people from the danger zone.
 - Notify your gas and power supply utility and your local heating contractor from outside the building.
 - Have the power supply to the building shut off from a safe place (outside the building).

If you smell flue gas



Danger

- Flue gas can lead to life threatening poisoning.
- Shut down the heating system.
 - Ventilate the installation site.
 - Close all doors in the living space.

Emergency contact

If you smell gas or detect a gas leak call the National Gas Emergency service on 0800 111 999. Notify your gas or electricity supplier and your heating contractor.

- Shut off the electricity supply to the building from a safe place (outside the building).

In case of fire



Danger

- Fire presents a risk of burns and explosion.
- Shut down the heating system.
 - Close the shut-off valves in the fuel supply lines.
 - Use a tested fire extinguisher, class ABC.

What to do if the heating system develops a fault



Danger

Fault messages indicate faults in the heating system. If faults are not rectified, they can have life threatening consequences. Do not acknowledge fault messages several times in quick succession. Inform your heating contractor so the cause can be analysed and the fault rectified.

For your safety (cont.)

Installation room requirements



Danger

Sealed vents result in a lack of combustion air. This leads to incomplete combustion and the formation of life threatening carbon monoxide.

Never cover or close existing vents.

Do not make any subsequent modifications to the building characteristics that could affect safe operation (e.g. cable/pipe-work routing, cladding or partitions).



Danger

Easily flammable liquids and materials (e.g. petrol, solvents, cleaning agents, paints or paper) can cause deflagration and fire. Never store or use such materials in the installation room or in direct proximity to the heating system.



Please note

Incorrect ambient conditions can lead to heating system damage and can put safe operation at risk.

- Ensure ambient temperatures are above 0 °C and below 35 °C.
- Prevent air contamination by halogenated hydrocarbons (e.g. as contained in paints, solvents or cleaning fluids) and excessive dust (e.g. through grinding/polishing work).
- Avoid continuously high humidity levels (e.g. through continuous drying of washing).

Extractors

The operation of appliances that extract air to the outside (cooker hoods, extractors, air conditioning units, etc.) can create negative pressure. If the boiler is operated at the same time, this can lead to reverse flow of the flue gas.



Danger

The simultaneous operation of the boiler and appliances that extract air to the outside can result in life threatening poisoning due to reverse flow of the flue gas.

Take suitable steps to ensure an adequate supply of combustion air. If necessary, contact your heating contractor.

Auxiliary components, spare and wearing parts



Please note

Components not tested with the heating system may damage the system or affect its function. Only allow qualified contractors to carry out installation or replacement work.

Index

Introductory information

Commissioning.....	7
Intended use.....	7
Terminology.....	7
Your system is preset at the factory.....	8
Energy saving tips.....	8

Where to find the controls

Summary of controls and indicators.....	9
■ Display and control elements.....	9
■ Symbols on the display.....	10
■ Operation.....	10
Operating mode of the heating system.....	10
■ Operation without room temperature controller.....	10
■ Operation with room temperature controller.....	11
■ Weather-compensated mode.....	11

Start-up/shutdown

Starting the heating system.....	12
Shutting down the heating system.....	13
Shutting down central heating and DHW heating.....	14
■ Shutting down central heating.....	14
■ Stopping DHW heating.....	14

Adjusting the room temperature

Setting the central heating temperature.....	15
■ Operation without room temperature controller — Setting the heating water temperature.....	15
■ Operation with room temperature controller — Setting the boiler water temperature.....	15
■ Weather-compensated operation — setting the room temperature.....	16

Setting the DHW temperature

DHW temperature.....	17
----------------------	----

Emissions test mode

Starting emissions test mode (to be used by a competent person only).....	18
■ Ending emissions test mode.....	18

What to do if...

Rooms are too cold.....	19
Rooms are too hot.....	19
There is no hot water.....	20

Index

Index (cont.)

The DHW is too hot..... 20

Upkeep

Cleaning..... 21

Inspection and maintenance..... 21

Boiler..... 21

Power cable..... 21

Appendix

Terminology..... 22

Keyword index..... 23

Commissioning

The commissioning and matching up of the control unit to local conditions and the structural characteristics of the building must be carried out by your heating contractor.

Intended use

The appliance is only intended to be installed and operated in sealed unvented heating systems that comply with EN 12828, with due attention paid to the associated installation, service and operating instructions. It is only designed for the heating of water that is of potable water quality.

Intended use presupposes that a fixed installation in conjunction with permissible, system-specific components has been carried out.

Commercial or industrial usage for a purpose other than heating the building or DHW shall be deemed inappropriate.

Any usage beyond this must be approved by the manufacturer in each individual case.

Incorrect usage or operation of the appliance (e.g. the appliance being opened by the system user) is prohibited and will result in an exclusion of liability. Incorrect usage also occurs if the components in the heating system are modified from their intended use (e.g. if the flue gas and ventilation air paths are sealed).

Terminology

To provide you with a better understanding of the functions of your Viessmann control unit, some terminology is explained.

The terms are marked as follows:



Further information can be found in chapter "Terminology" in the appendix.

Introductory information

Your system is preset at the factory

Your heating system is preset at the factory and is therefore ready for operation. DHW and central heating are enabled. Your heating contractor can make further adjustments for you during commissioning. You can change these settings at any time to suit your individual requirements.

Power failure

All settings are saved if there is a power failure.

Energy saving tips

Central heating

- **Room temperature:**
Never overheat your rooms. Every degree of room temperature reduction saves up to 6 % on your heating bills. If possible, set your room temperature no higher than 20 °C (see page 15).
- **Ventilation:**
For venting/airing, open the windows fully for a brief time. During this time, close the thermostatic valves (if no mechanical ventilation system is installed).
- **Roller shutters:**
Close roller shutters (where installed) at dusk.
- **Thermostatic valves:**
Ensure that thermostatic valves are properly adjusted.
- **Radiators:**
Never cover radiators or thermostatic valves.

DHW heating

- **DHW temperature:**
Never set the DHW temperature too high (see page 17).
- **Hot water consumption:**
Consider showering instead of running a bath. A shower generally uses less energy than a full bath.

Summary of controls and indicators

Display and control elements

You can change any settings on your heating system centrally at the control unit.

Note

If your system is equipped with a room temperature controller, you can use it to set the room temperature (see separate operating instructions)..

All thermostatic radiator valves must be fully open in the room where the room temperature controller is installed.

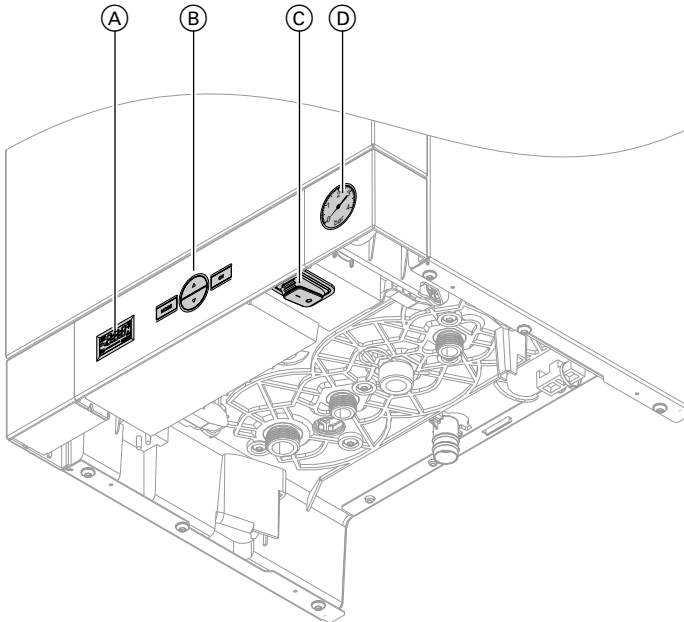

(A) Display

(B) Keys (see page 10)

(C) ON/OFF switch

(D) Pressure gauge

Where to find the controls

Summary of controls and indicators (cont.)

Symbols on the display

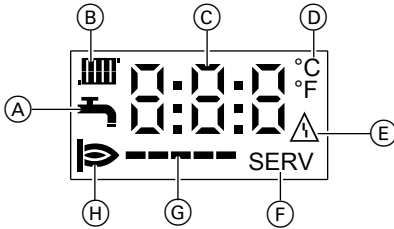

- | | |
|---------------------------------------|---------------------------|
| (A) DHW heating | (E) Fault display |
| (B) Heating mode | (F) Service mode |
| (C) Display value or fault code | (G) Current burner output |
| (D) Temperature displayed in °C or °F | (H) Burner operation |

Operation

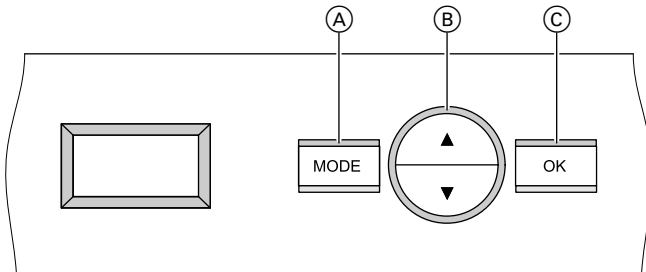

- | | |
|-------------------------------------|---|
| (A) Selecting/terminating functions | (C) Accepting values/confirming selection |
| (B) Changing or selecting values | |

Operating mode of the heating system

Operation without room temperature controller



Further information can be found in chapter "Terminology" in the appendix.

Setting the required heating water temperature, see page. 15.

Operating mode of the heating system (cont.)

Operation with room temperature controller



Further information can be found in chapter "Terminology" in the appendix.

Make any settings on the connected room temperature controller using the relevant operating instructions.

Note

Set the boiler water temperature set high enough in order to achieve the required room temperature.

For settings, see page 15.

Weather-compensated mode



Further information can be found in chapter "Terminology" in the appendix.

The boiler water temperature is regulated in accordance with a defaulted heating curve and the prevailing outside temperature.

For setting the room temperature, see page 16.

Note

Connect a room temperature controller to your heating system to prevent generating heat unnecessarily at times when you do not require central heating. This enables central heating to be suspended at night, for example, in order to save energy.

Start-up/shutdown

Starting the heating system

We recommend you contact your heating contractor if you are planning to take your heating system out of use for long periods.

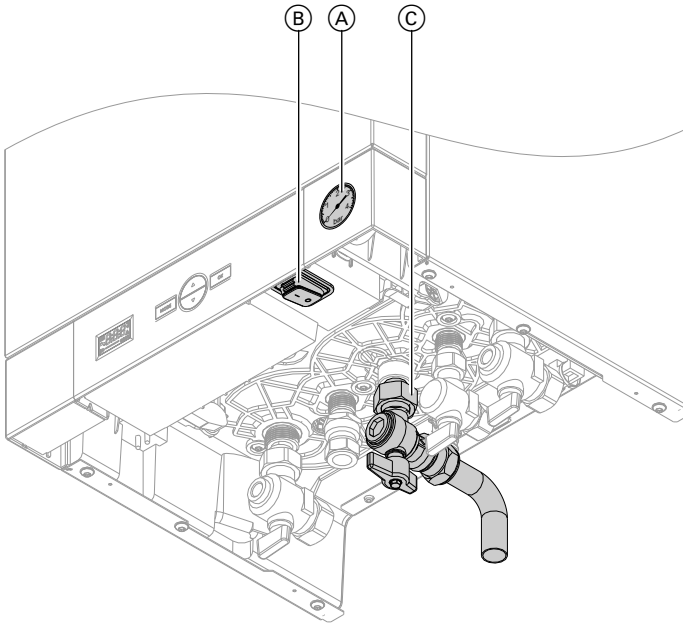

1. Check the heating system pressure at pressure gauge (A):
The system pressure is too low if the indicator points to the area below 0.8 bar (80 kPa). In this case, top up with water or notify your local heating contractor. When topping up the system with water the pressure (cold) should not exceed 1.5 bar.
2. Open gas shut-off valve (C).
3. Switch ON the power supply, e.g. at a separate MCB/fuse or a mains isolator.
4. Switch ON/OFF switch (B) ON.
The control unit carries out a self test after being switched ON.
Your heating system and room temperature controller (if installed) are now ready for operation.

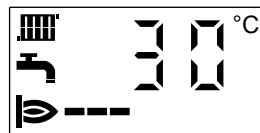

Note
Boiler frost protection is enabled.

Starting the heating system (cont.)



Please note

Frost protection is only ensured for as long as the power supply is stable. Switch ON the power supply (MCB/fuse, mains isolator) and the control unit ON/OFF switch.

Shutting down the heating system

- If you do not intend using your heating system for a while, such as during a summer holiday, switch off central heating and DHW heating (see page 14).
- You can switch your heating system OFF at the ON/OFF switch if you do not intend using it. We recommend you contact your heating contractor if you are planning to take your heating system out of use for long periods. Your heating contractor can then take suitable steps such as frost protection for the system or heating surface preservation as required.

Shutting down the heating system

1. Switch ON/OFF switch **(B)** OFF. The display goes blank.
2. Close gas shut-off valve **(C)**.

Note

*The system is **no longer** protected against frost.
All control unit settings are retained.*

Start-up/shutdown

Shutting down central heating and DHW heating

Shutting down central heating

You do not want to heat your interior but you want to have DHW available (summer mode).

Press the following keys:

1. ▼ the set boiler water temperature flashes and  will be displayed.
2. ▼ until "OFF" is displayed.



3. **OK** to confirm.

Note

- The circulation pump briefly starts every 24 hours to prevent it from seizing up.
- Boiler frost protection is enabled.

Stopping DHW heating

You do not want to have DHW available

Press the following keys:

1. **MODE**
2. ▲/▼ until  flashes.
3. **OK** to confirm.
The set DHW temperature flashes.

4. ▼ until "OFF" is displayed.



5. **OK** to confirm.

Setting the central heating temperature

Operation without room temperature controller — Setting the heating water temperature

If no outside temperature sensor and no room temperature controller is connected.

The room temperature is influenced by the heating water temperature. In the delivered condition, the heating water temperature is set to 70 °C.

Press the following keys:

1. ▲/▼ the set heating water temperature flashes and  will be displayed.

2. ▲/▼ until the required heating water temperature is displayed.

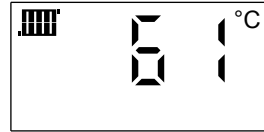

3. OK to confirm.

Operation with room temperature controller — Setting the boiler water temperature

If no outside temperature sensor is connected, but a room temperature controller is.

Set the boiler water temperature high enough if the required room temperature cannot be achieved. In the delivered condition, the boiler water temperature is set to 70 °C.

Press the following keys:

1. ▲/▼ the set boiler water temperature flashes and  will be displayed.

2. ▲/▼ until the required boiler water temperature is displayed.

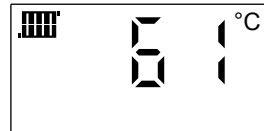

3. OK to confirm.

Adjusting the room temperature

Setting the central heating temperature (cont.)

Weather-compensated operation — setting the room temperature

An outside temperature sensor must be connected for weather-compensated operation.

In the delivered condition, a parameter value of 20 is set for central heating. Should you wish to set a higher room temperature, increase the parameter value; reduce it for a lower room temperature.

Press the following keys:

1. ▲/▼ the set parameter flashes and  will be displayed.
2. ▲/▼ until the required room temperature is achieved.

Note

When adjusting this setting, bear in mind that your heating system requires some time to heat the interior to the required temperature.



3. **OK** to confirm.

DHW temperature

Press the following keys:

1. MODE

2. ▲/▼ until  flashes.

3. OK to confirm.
The set DHW temperature flashes.

4. ▲/▼ to set the required DHW temperature.



5. OK to confirm.

Emissions test mode

Starting emissions test mode (to be used by a competent person only)

Emissions test mode should only be activated by your flue gas inspector during the annual inspection. Various output stages can be set for checking the flue gas.

Press the following keys:

1. MODE

2. ▲/▼ until "**SERV**" flashes.

3. OK to confirm.
"**OFF**" flashes (test mode disabled).

4. ▲/▼ to set the required burner output.

Display	Display	Burner output
-	20	20 %
--	40	40 %
---	60	60 %
----	80	80 %
-----	100	100 %

5. OK to confirm.
Test mode enabled.

Ending emissions test mode

Note

This function will also terminate automatically after 30 minutes.

Press the following keys:

1. MODE

2. ▲/▼ until "**SERV**" flashes.

3. OK to confirm. The value set last flashes.

4. ▼ until "**OFF**"flashes.

5. OK to confirm.
Test mode is now disabled.

Rooms are too cold

Cause	Remedy
Room temperature controller incorrectly set.	Set the required room temperature at the room temperature controller.
The heating system is switched off.	<ul style="list-style-type: none"> ■ Switch the ON/OFF switch ON. ■ Switch the mains isolator ON (if installed). ■ Check the MCB/fuse in the power distribution board (main domestic MCB/fuse).
Control unit incorrectly set.	<ul style="list-style-type: none"> ■ Operation with room temperature controller: Set a higher boiler water temperature (see page 15). ■ Weather-compensated operation: Set a higher room temperature (see page 16).
Symbol  flashes and a fault code (e.g. F2) will be displayed.	Notify your local heating contractor. The indication disappears when the fault has been removed.
No fuel.	<p>Open the gas shut-off valve.</p> <ul style="list-style-type: none"> ■ If necessary, check with your gas supply utility.

Rooms are too hot

Cause	Remedy
Room temperature controller incorrectly set.	Set the required room temperature at the room temperature controller.
Control unit incorrectly set.	<ul style="list-style-type: none"> ■ Operation with room temperature controller: Set a lower boiler water temperature (see page 15). ■ Weather-compensated operation: Set a lower room temperature (see page 16).
SERV is displayed (the service function has been enabled).	The service function will terminate automatically no later than after 30 minutes.

What to do if...

There is no hot water

Cause	Remedy
Heating system switched off.	<ul style="list-style-type: none">■ Switch the ON/OFF switch ON.■ Switch the mains isolator ON (if installed).■ Check the MCB/fuse in the power distribution board (main domestic MCB/fuse).
Control unit incorrectly set.	Set a required DHW temperature (see page 17).
Symbol Δ flashes and a fault code (e.g. F2) will be displayed.	Notify your local heating contractor. The indication disappears when the fault has been removed.
No fuel.	Open the gas shut-off valve. <ul style="list-style-type: none">■ If necessary, check with your gas supply utility.

The DHW is too hot

Cause	Remedy
Control unit incorrectly set.	Set a required DHW temperature (see page 17).
SERV is displayed (the service function has been enabled).	The service function will terminate automatically no later than after 30 minutes.

Cleaning

The appliance may be cleaned with a commercially available domestic cleaning agent (non-scouring).

Inspection and maintenance

The inspection and maintenance of a heating system is prescribed by the Energy Saving Ordinance [EnEV - Germany] and the DIN 4755, DVGW-TRGI 2008 and DIN 1988-8 standards.

Regular maintenance ensures trouble-free, energy efficient and environmentally responsible heating. For this, we strongly advise you to arrange an inspection and maintenance contract with an authorised heating contractor.

Boiler

Increasing boiler contamination raises the flue gas temperature and thereby increases energy losses. All boilers should therefore be cleaned annually.

Power cable

Never replace faulty power cables. Have a qualified electrician replace faulty cables.

Terminology

Heating water temperature

The temperature of the heating water that flows to the radiators (roughly equal to boiler water temperature).

Boiler water temperature

The heating water in the boiler (boiler water) is heated to the temperature set at the control unit. This temperature is referred to as boiler water temperature.

Room temperature-dependent operation

A room temperature controller captures the room temperature and compares this with the required room temperature you set. If the room temperature is lower than the required value, the boiler is switched on; if the room temperature is higher than the required value, the boiler is switched off.

Make any settings on the connected room temperature controller using the relevant operating instructions.

Note

The boiler water temperature must be set high enough in order to achieve the required room temperature.

Safety valve

A safety device (pressure relief valve) which must be installed in the cold water pipe if the mains water pressure exceeds 10 bar. The safety valve opens if a certain pressure has been reached.

Flow temperature

The temperature of the heating water that flows to the radiators (in the flow line). Accordingly, the temperature of the heating water that flows from the radiators to the boiler (in the return line) is referred to as return temperature.

Weather-compensated operation

In weather-compensated mode, the boiler water temperature is regulated according to the prevailing outside temperature. For this, a temperature sensor mounted outside the building envelope must be connected to your heating system.

The outside temperature is captured and transmitted to the control unit by this sensor.

Keyword index

B

- Boiler water temperature.....15
- Explanation.....22

C

- Central heating
 - Energy saving.....8
- Cleaning.....21
- Commissioning.....12
- Controls.....9

D

- DHW heating
 - Energy saving.....8
- DHW temperature.....17
- DHW too hot.....20
- Display.....10
- Display elements.....9

E

- Emissions test mode.....18
- Energy saving (tips).....8

F

- Fault display.....19, 20
- Flow temperature
 - Explanation.....22
- Frost protection.....12, 13, 14

G

- Gas shut-off valve.....12, 13
- Glossary.....22

H

- Heating
 - Energy saving.....8
- Heating water temperature
 - Explanation.....22
 - Setting.....10, 11

I

- Inspection.....21

K

- Keys.....9

M

- Maintenance.....21

N

- No hot water.....20

O

- ON/OFF switch.....9, 12
- Outside temperature.....11

P

- Power failure.....8
- Pressure gauge.....9, 12
- Programming unit.....9

R

- Remote control.....11
 - With.....11
 - Without.....10
- Rooms are too cold.....19
- Room temperature.....10
 - Energy saving.....8
 - Setting.....10, 11
- Room temperature controller
 - With.....11
 - Without.....10
- Room temperature-dependent operation
 - Explanation.....22
- Room thermostat.....9
- Rotary selector.....10

S

- Safety valve
 - Explanation.....22
- Service function.....19, 20
- Setting the room temperature.....15
- Shutting down.....13
- Shutting down central heating.....14
- Shutting down the system.....13

Keyword index

Keyword index (cont.)

Standby mode.....	13	Test mode.....	18
Starting the system.....	12	Tips	
Stopping DHW heating.....	14	– Energy saving.....	8
Summer mode.....	14	Troubleshooting.....	19, 20
Switching off a heating circuit.....	14	W	
Switching off central heating/DHW heating.....	14	Weather-compensated mode.....	11
Symbols.....	10	Weather-compensated operation	
		– Explanation.....	22
T		Window ventilation.....	8
Temperature, changing.....	10		
Terminology.....	22		

Your contact

Contact your local contractor if you have any questions regarding the maintenance and repair of your system. You may, for example, find local contractors on the internet under www.viessmann.com.

Viessmann Werke GmbH&Co KG
D-35107 Allendorf
Telephone: +49 6452 70-0
Fax: +49 6452 70-2780
www.viessmann.com

Viessmann Limited
Hortonwood 30, Telford
Shropshire, TF1 7YP, GB
Telephone: +44 1952 675000
Fax: +44 1952 675040
E-mail: info-uk@viessmann.com

Subject to technical modifications.
5513 086 GB